



## Optical & Video Measuring System

For inspection and measurement of 2-dimensional parts

- 2-axis non-contact measurement
- Patented optical image clearly defines edges, offering superb resolution and contrast
- Video edge detection for higher throughput measurements
- Powerful and intuitive touch-screen video microprocessor delivers simple, fast results
- High accuracy, low investment system

# 2-Axis Optical & Video Measuring System



The Peregrine non-contact measuring microscope utilises Vision Engineering's patented Dynascope™ technology together with an advanced touch-screen video microprocessor, providing the benefit of both optical and video measurement.

Vision Engineering's Peregrine measuring microscope provides fast and accurate 2-axis measurement of precision component parts, suitable for both shop-floor quality control and manufacturing inspection applications.

Peregrine empowers users with options of optical and/or video measurement, providing the ability to perform high accuracy optical measurements for difficult-to-view subjects and critical parts, or higher volume video measurements for high contrast subjects or batch routines. From manual, single-feature operation to higher throughput video edge detection measurements, Peregrine optimises measurement routines to deliver accuracy and simplicity for a wide range of measuring applications.

## Patented Technology

Vision Engineering's patented Dynascope™ technology offers the user a superior optical image of the subject making it easy to accurately measure small intricate parts.

Difficult-to-view features such as low contrast black or white plastics, materials of different colours and textures, or transparent parts may all be viewed in intricate detail. The superb optical clarity also allows detailed visual inspection to be performed simultaneously.

## Video Measurement

Peregrine, with a 150mm x 100mm stage, is ideal for measuring 2-D features of small, intricate parts and incorporates a video camera with advanced touch-screen QC-300 microprocessor.



QC-300 features an array of video measurement tools, including simple crosshair measurement, manual or automatic single point detection and multi-point video edge detection.

The intuitive QC-300 software can be used by shift workers or advanced users and accommodates multiple languages including English, French, German, and Italian.

- 2-axis non-contact measurement
- Patented optical image clearly defines edges, offering superb resolution and contrast
- Video measurement for fast, higher throughput measurements
- Powerful and intuitive touch-screen video microprocessor delivers simple, fast results
- Intuitive touch-screen colour display can be used by shift workers or advanced users alike
- High accuracy, low investment system



## Features & Benefits

- Ideal for rapid measurement and inspection of small components, providing a crisp, high contrast image of the subject
- Stage travel of 150mm in X-axis and 100mm in Y-axis and accommodates components up to 10kg

## Precision Measuring Stage

- 150mm x 100mm precision measuring stage has factory completed non-linear error correction to ensure optimum accuracy, traceable to International standards for the purposes of ISO9000
- 1µm resolution glass measuring encoders ensure the highest levels of precision

## Illumination

- Surface and sub-stage illumination options enable adjustment of lighting to suit any application. A range of surface illumination options are available, including semi-coaxial spotlamps, 6-point fibre-optic ring light and an episcopic (through the lens) illuminator for viewing blind bores or deep surface features. Substage illumination provides the ability to measure profiles.

# QC-300 Video Microprocessor



Quadra-Chek digital readouts and metrology software are the premier systems for the measurement and inspection of 2-D geometric components.

A QC-300 video microprocessor is the standard control interface with the Peregrine non-contact measuring system, providing a powerful combination to empower operators along every step of the measurement process. Patented features reduce repetitive measurements and simplify complex work steps.

## Intuitive User Interface

QC-300 features a powerful and intuitive interface which can be used by shift workers or advanced users alike. The high resolution touch-screen colour display is exceptionally easy to use and ensures operator accuracy with minimal training time.

## Video Measurement Tools

Switch from simple crosshair measurement to automatic video edge detection for form measurement inside or outside the field of view. QC-300 features an array of powerful and flexible video measurement tools to speed up and simplify the measurement process, including simple crosshair measurement, offset crosshair for difficult-to-find edges, manual or automatic single point detection and multi-point video edge detection.

## Part Programming

Programme a measurement sequence once and run it back as often as you need. Measure the same number of points per feature, in the identical sequence, part after part.

## Intersections and Constructions

Obtain essential intersection and construction results by selecting from the list of previously measured features, complete with graphics.

## Geometric Tolerancing

QC-300's unique graphical representation instantly views pass/fail performance details for critical part dimensions.

## Image Capture and Analysis

QC-300 captures video images (in .jpeg format) to either internal memory or directly to the USB port. The image can then be edited or appended with text and measurement data.

## Measure Magic®

To measure, simply probe points and click. QC-300 detects, without the operator's intervention, the feature type being measured. Operators can inspect multiple features without taking their eyes off the part, increasing throughput, improving accuracy and reducing user fatigue.

## Options

Get the right tools for the job. Optional remote keypads, footswitches and printers help operators capture the precise measurement data more conveniently while streamlining the work process.

## Connectivity

Connectivity includes USB, parallel and serial ports for use with printers and computer networks.

## Languages

QC-300 accommodates multiple languages, including English, French, German and Italian.



Automatic video edge detection

Data cloud with errors

Tolerance displays

# Technical Specifications



## Optical

- Twin pupil monoscopic, infinity corrected optical system utilising patented Dynascope™ Technology
- Pre-centred crossline graticule to both eyes
- Custom designed graticule, pre-centred to one eye (optional)

## Video

- 1/3" CCD (795 x 596 resolution) interline image sensor
- Composite video 1 Vp-p 75ohm unbalanced
- Selectable backlight compensation
- Low light sensitivity – 4.0 LUX at F1.2
- Power supply – DC +10.8~13.2v (12v±10%)

## Illumination

- Surface illumination provided by 2 x 30W semi-coaxial spot lamps with integral power supply - 600 hours
- 30W substage illumination for profile measurement - 600 hours
- 150W semi-coaxial 6-point ringlight with free-standing fibre-optic illuminator and power supply - 200 hours (optional)
- 100W episcopic (through the lens) illuminator for viewing blind bores or deep surface features - 200 hours (optional)

## Measuring Stage

- 150mm x 100mm
- Factory installed non-linear error correction (NLEC) calibration to ensure optimum accuracy, traceable to International standards for the purposes of ISO9000
- 1µm encoder resolution
- 10kg max. glass plate load

## Measurement Uncertainty

$$U_{95}2D = 7 + (6.5L/1000)\mu m^*$$

\*where L = length in mm (x50 system magnification, controlled 20°C, using traceable chrome on glass grid artefact, with intersection points at the standard measuring plane).

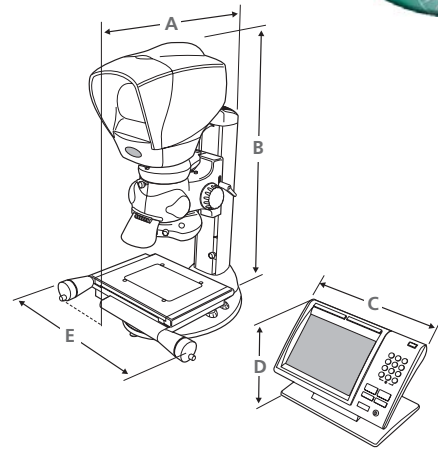

## Dimensions

- A = 490mm
- B = 645mm
- C = 285mm
- D = 210mm
- E = 405mm

## Weight

	Packed	Unpacked
Head	5kg	4kg
Focus Assembly/Illumination/Camera/ Camera Adapter	4.5kg	3.5kg
Stand/Stage	16.5kg	14kg
Microprocessor	7kg	6kg

## Optical Information

Objective Part Number	System Magnification	Working Distance	Field of View
K-007	x10	81mm	14.2mm
K-008	x20*	81mm	7.1mm
K-009	x50	61mm	2.9mm

\*standard option

For more information...

Vision Engineering has a network of offices and technical distributors around the world. For more information, please contact your Vision Engineering branch, local authorised distributor, or visit our website.

Vision Engineering Ltd.  
(Manufacturing)  
Send Road, Send, Woking,  
Surrey, GU23 7ER, England  
Tel: +44 (0) 1483 248300  
Fax: +44 (0) 1483 223297  
Email: generalinfo@visioneng.com

Vision Engineering Inc.  
(Manufacturing & Commercial)  
570 Danbury Road,  
New Milford, CT 06776 USA  
Tel: +1 (860) 355 3776  
Fax: +1 (860) 355 0712  
Email: info@visioneng.com

Vision Engineering Ltd.  
(Central Europe)  
Anton-Pendele-Str. 3,  
D-82275, Emmering, Germany  
Tel: +49 (0) 8141 40167-0  
Fax: +49 (0) 8141 40167-55  
Email: info@visioneng.de

Vision Engineering Ltd.  
(France)  
ZAC de la Tremblaie, Av. de la Tremblaie  
91220 Le Plessis Paté, France  
Tél: +33 (0) 160 76 60 00  
Fax: +33 (0) 160 76 60 01  
Email: info@visioneng.fr

Vision Engineering Ltd.  
(Commercial)  
Monument House, Monument Way West,  
Woking, Surrey, GU21 5EN, England  
Tel: +44 (0) 1483 248300  
Fax: +44 (0) 1483 248301  
Email: generalinfo@visioneng.com

Vision Engineering Inc.  
(Commercial West Coast USA)  
745 West Taft Avenue,  
Orange, CA 92865 USA  
Tel: +1 (714) 974 6966  
Fax: +1 (714) 974 7266  
Email: info@visioneng.com

Nippon Vision Engineering  
(Japan)  
272-2 Saedo-cho, Tsuduki-ku,  
Yokohama-shi, 224-0054, Japan  
Tel: +81 (0) 45 935 1117  
Fax: +81 (0) 45 935 1177  
Email: info@visioneng.jp

Vision Engineering Ltd.  
(Italy)  
Via Cesare Cantù, 9  
20092 Cinisello Balsamo MI, Italy  
Tel: +39 02 6129 3518  
Fax: +39 02 6129 3526  
Email: info@visioneng.it

Distributor

Visit our multi-lingual website:

[www.visioneng.com](http://www.visioneng.com)