

Prizmatix

UHP-Mic-LED-520

Ultra High Power LED Light Source for Fluorescence Microscope

Introduction

The Ultra High Power LED provides almost x10 increase of power in comparison with similar High Power LED devices. The Ultra High Power LED is an effective replacement of lasers and lamps in many power demanding applications, such as fluorescence microscopy, machine vision, chemical reaction activation and numerous others.

This new member of the modular OptiBlocks family provides **>0.5 Watt of collimated Green LED** power on its output. The LED driver supports CW or pulsed operation.

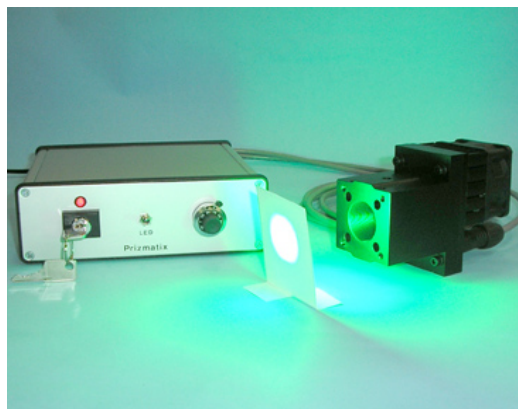

Key Features

- Compatible with Prizmatix modular Microscope-LED Light Source products family
- TTL external triggering
- Excellent for fluorescence excitation
- LED spectrum can be narrowed by optional band pass filter installed inside the head.
- Stable precisely adjustable power
- Long life (no lamp or laser tube replacement required)
- Speckle free
- Rapid warm up time

Applications

- Fluorescence microscopy (Alexa Fluor 514, Cy3, SNAFL[®], SNARF[®], FM 4-64)
- Whole body imaging of small animals in-vivo
- Photo activation (PA)
- Fluorescence recovery after photo bleach (FRAP)
- Fluorescence in situ hybridization (FISH)
- Bio analysis
- Machine Vision

Main Office

Phone: +972-8-929-7844
Fax: +972-8-929-8772
sales@prizmatix.com

European Sales Office

Phone: +44 (0)77-9172-9592
Fax: +44 (0)20-7681-2977
sales.europe@prizmatix.com

North America Sales Office

Phone: +1-(248)-436-8085
Fax: +1-(248)-281-5236
sales.usa@prizmatix.com

16 Or-Hahaim St., P.O.B. 4234 Modiin-Ilite 71919, Israel

Prizmatix

Optical Specifications

Wavelength	nm	520
Wavelength range	nm	±5
Spectrum half width	nm	36
Collimated optical power output	mW	>500

Benchtop LED Current Controller Specifications

Features

- Constant current or chopping modes
- Precise LED current setting by 10 turn dial
- TTL external trigger input
- Compact and robust enclosure

Digital modulation input		TTL
Connector for TTL input		BNC
Digital modulation frequency	Hz	DC-30000
Rise / Fall time (10% - 90%)	µs	2
ON/OFF extinction		>10 ⁶ : 1
Input Voltage	V	12
Max Input current	A	5.5
Power Adaptor Input		100-240 VAC, 50-60Hz, 1.5A

General Specifications

Operation temperature range	°C	10-35
Storage temperature range	°C	-10-55
Operating relative humidity (Non condensing)	%	<90
Head dimensions		See drawing below
Head weight	g	500
Controller dimensions (LxWxH)		220mm x 165mm x 51.5mm
Controller weight	g	700
Power adaptor dimensions (LxWxH)		146mm x 76mm x 44mm
Power adaptor weight	g	600
Fan noise	dBA	38

Main Office

Phone: +972-8-929-7844
Fax: +972-8-929-8772
sales@prizmatix.com

European Sales Office

Phone: +44 (0)77-9172-9592
Fax: +44 (0)20-7681-2977
sales.europe@prizmatix.com

North America Sales Office

Phone: +1-(248)-436-8085
Fax: +1-(248)-281-5236
sales.usa@prizmatix.com

16 Or-Hahaim St., P.O.B. 4234 Modiin-Ilite 71919, Israel

Prizmatix

Performance

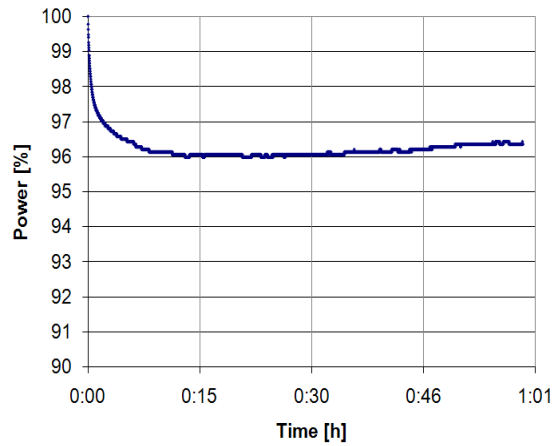
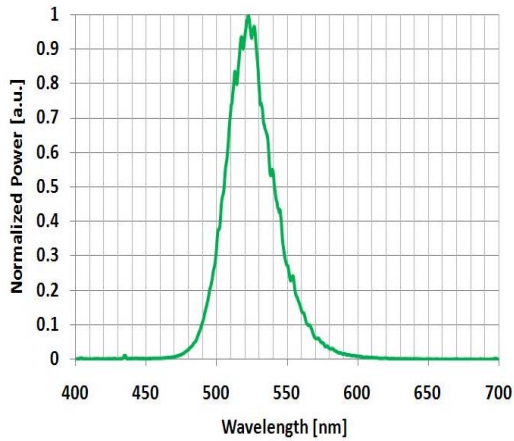

- UHP-Mic-LED-520 spectrum
- UHP-Mic-LED-520 Stability

Mechanical Drawings

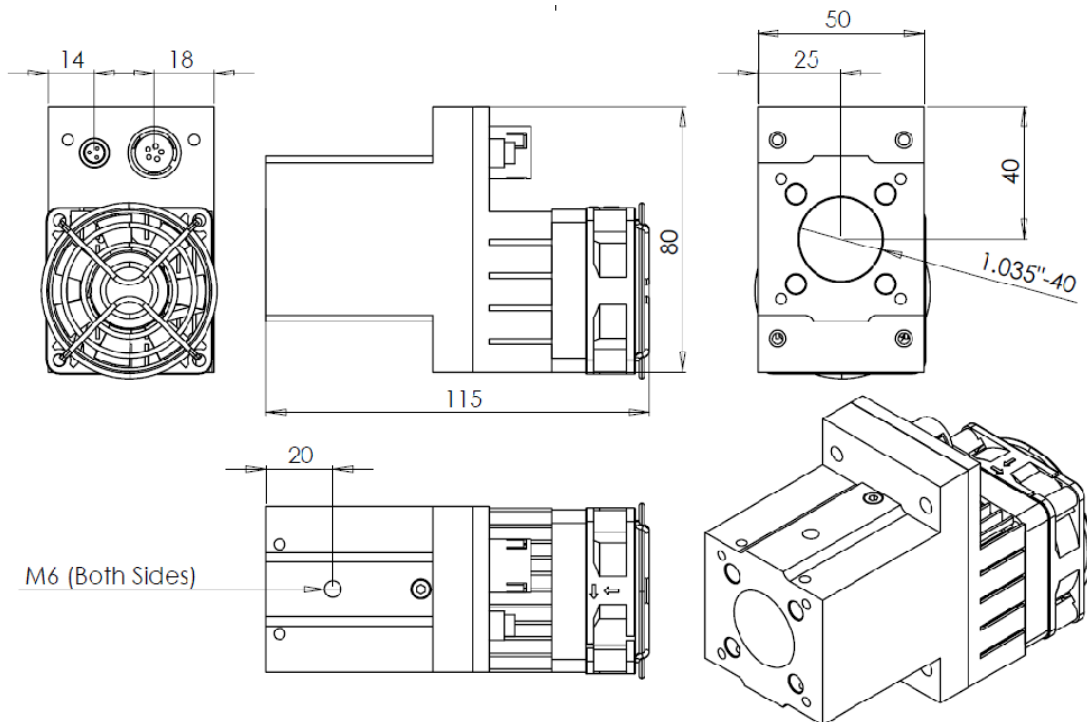

Main Office

Phone: +972-8-929-7844
Fax: +972-8-929-8772
sales@prizmatix.com

European Sales Office

Phone: +44 (0)77-9172-9592
Fax: +44 (0)20-7681-2977
sales.europe@prizmatix.com

North America Sales Office

Phone: +1-(248)-436-8085
Fax: +1-(248)-281-5236
sales.usa@prizmatix.com

16 Or-Hahaim St., P.O.B. 4234 Modiin-Ilite 71919, Israel